

# Quick Reference Guide

**Keep with unit.**

**On initial startup, allow 20 minutes warmup time.**

This Guide will help with daily operation after the unit has been properly installed by a trained professional. Please take the time to become familiar with the unit and its instruction manuals.

## A Quick Tour of Key Components

### Looking at the Front (Café IV Shown)

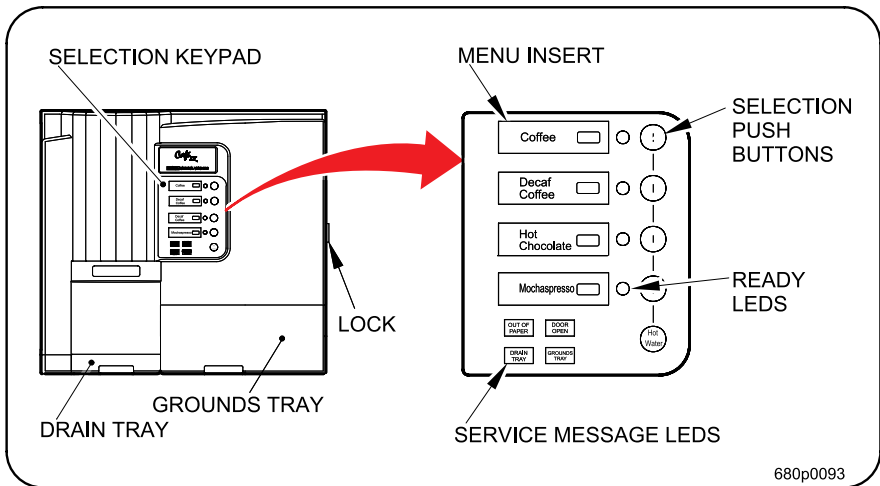

### Just Inside the Door

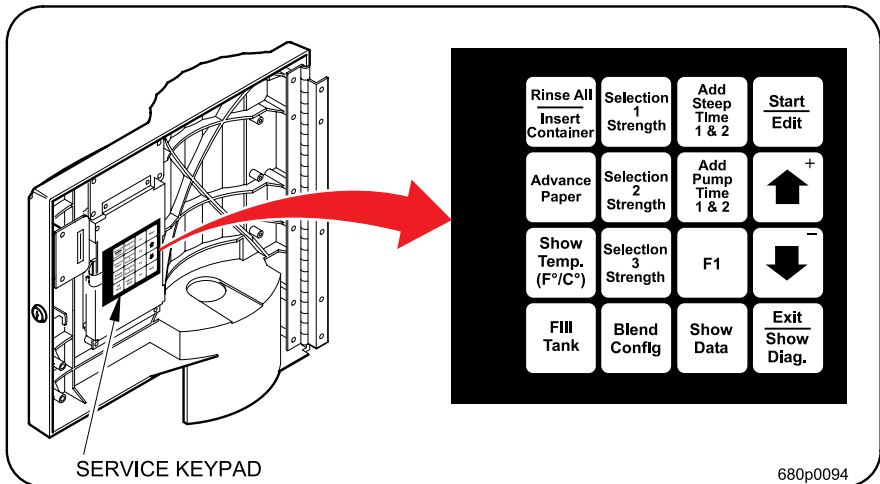

## Looking Inside the Cabinet (Café III Shown)

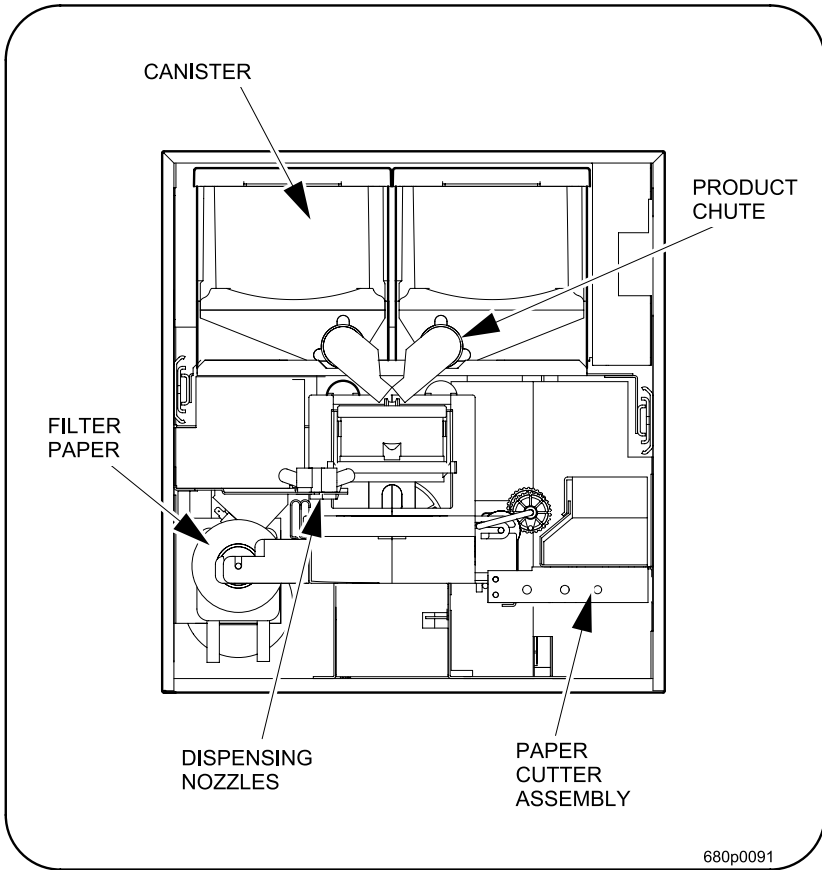

### Safety First

Following a few simple guidelines will ensure safe use of this Café unit.

- 1 - Coffee, gourmet coffee, and hot chocolate require hot water. Temperatures can exceed 170°F. Be careful!—especially with the drain tray and freshly made drinks.
- 2 - Never remove covers on electrical components, and do not use spray cleaners inside the unit.
- 3 - The cutter assembly blade is very sharp. Use a plastic knife or spoon to clear the assembly.

## Normal Operation

- 1 - Place cup on cup station and press the button for the desired drink selection. (Press the button twice for an extra strong drink.)
- 2 - Expect a short pause before brewing starts. Wait until the brewing and dispensing cycle stops. During the brewing cycle, the ready light will flash. (The ready light will flash at a different rate for an extra strong drink.)

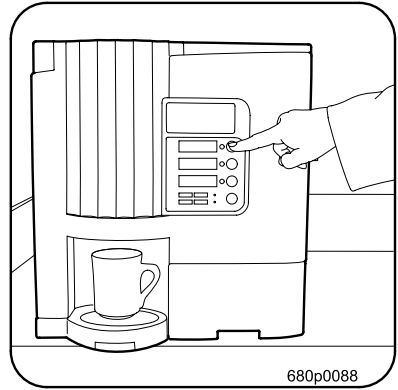

**Service Message LEDs call for specific action to bring the unit back to normal operation.**

OUT OF PAPER

Replace filter paper roll.

DOOR OPEN

Close and secure the door.

GROUND'S TRAY

Empty and replace grounds tray.

DRAIN TRAY

Empty and replace drain tray.

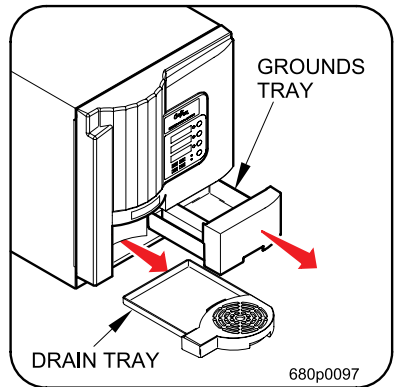

- To empty either the grounds tray or the drain tray, pull the tray slowly, but firmly out from the unit. Exercise caution, since liquids in the trays may be very hot. ***The trays must stay out of the unit at least six seconds for unit to reset when they are replaced.***
- When replacing a tray be sure it is completely seated or the Service message LED will remain on and the unit will not operate.

## Quick Checks

**Watery Coffee or Hot Chocolate** - Check canisters and chutes.

**No Ready Lights** - Check outlet plug and circuit breaker or fuse.

**All Ready Lights Flashing** - Water is heating.

**No Ready Lights for Brewed Drinks** - Check paper cutter for jams.

## Loading or Replacing the Filter Paper

(Wash hands first.)

1 - Remove the spent filter paper roll:

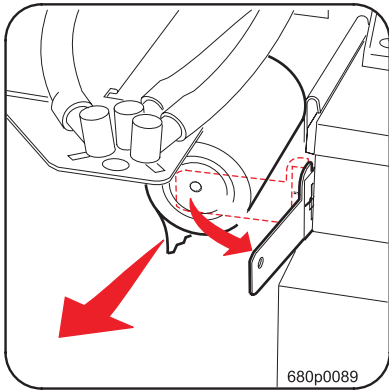

a. Swing the filter paper holder out and pull the spent roll from the shaft.

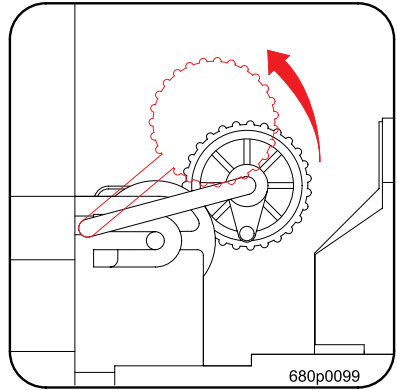

b. Lift the idler roller as shown, freeing the paper.  
c. Discard the spent filter paper.

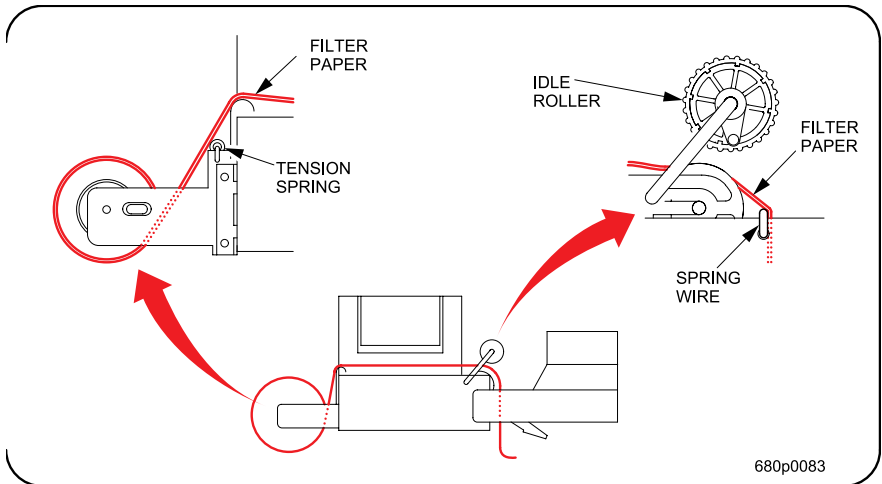

2 - Install a new roll so it feeds from the bottom. ***Be sure it goes over the tension spring as shown.***

3 - Route the filter paper as shown. Lift the idler rollers, feeding the paper under them, but ***over the spring wire.***

4 - Close the unit's door and make one test drink.

5 - Open the door and check to see if the filter paper advanced properly. Close the door for normal operation.

## Filling the Canisters

(Wash hands first.)

- 1 - Turn the product chutes up to prevent spilling.

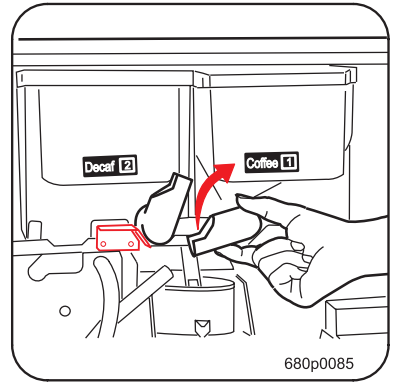

- 2 - Pull the canister shelf forward.

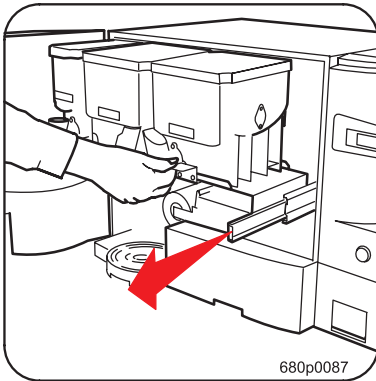

- 3 - Fill each canister. Maximum fill level is one inch below the top of the canister. **Do not overfill.**

- 4 - Push the canister shelf back into the cabinet until it “clicks” in place.

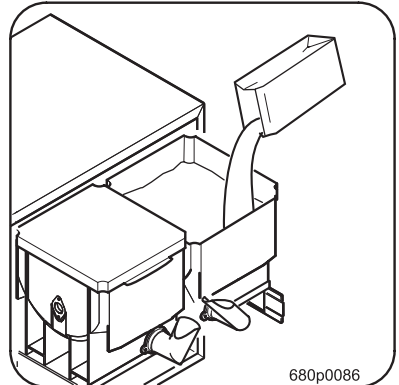

CORRECT PRODUCT  
CHUTE POSITION  
FOR DISPENSING  
PRODUCT

CHUTE  
STOP

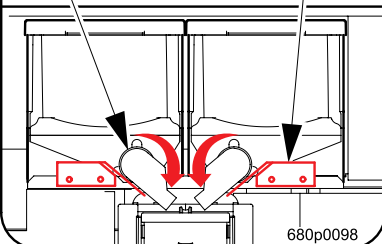

- 5 - **Turn the canister chutes back down.** The chutes must be resting on the chute stops or pointed straight down. Close the door for normal operation.

## Cutter Clearing Procedure

If the paper cutter jams the Ready LEDs for brewed drinks will go out.

### To clear the jam:

- 1 - Open the door. Do NOT touch any switches or buttons. Empty the grounds tray if needed.
- 2 - Clear the jam. Using a plastic knife or spoon, press the paper and grounds through the cutter assembly and into the grounds tray.

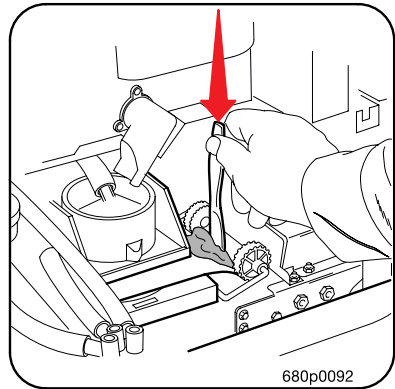

### Warning:

The cutter assembly blade is very sharp.  
Do NOT clear directly with a finger.

- 3 - Inspect the filter paper track to see that it is straight and clear of excessive grounds.
- 4 - On the service keypad press the **Advance Paper** Button to reset the machine. **NOTE: Paper will not advance.**
- 5 - Close the door. Brew a trial drink. Open the door to verify the paper and grounds advanced properly.

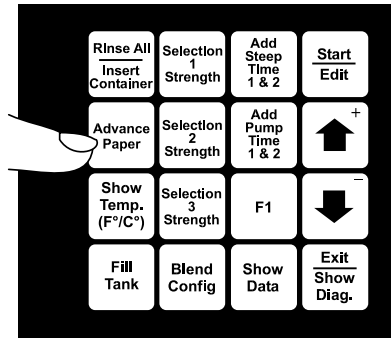

## Clean the Machine Every Day

1 - Perform a rinse cycle.

- a. Put an empty container able to hold at least 24 ounces at the cup station. Pull out the door switch and press the ***Rinse All/Insert Container*** button.

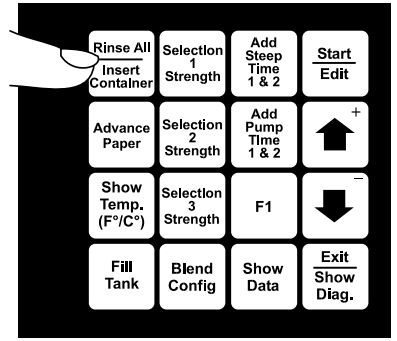
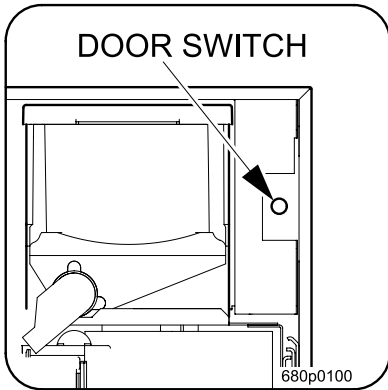

b. The following occurs in sequence for all selections:

- For brewed selections, the brew barrel is flushed, then the filter paper advances and is cut.
- For non-brewed selections, the mixing bowl and whipper are flushed.

2 - Remove the drain tray and grounds tray. Empty and clean them.

3 - Wipe out the bottom of the cabinet with a clean damp cloth.

4 - Wipe off any spills on the inside of the door.

5 - Wipe off the outside of the machine and cup station.

6 - Replace the drain tray and grounds tray.